

High Pressure Line 80

Type: 36800-B

Design meets the requirements of PED 2014/68/EU and harmonized standards

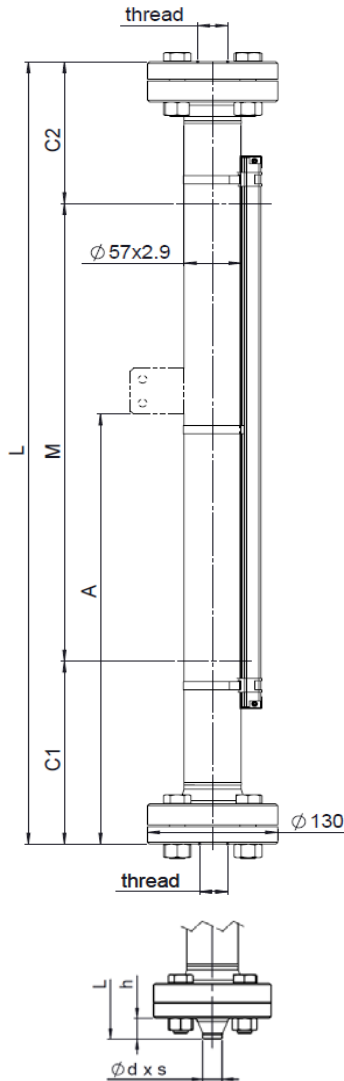

Float extension lower / upper:

	C1:	C2:
Standard	200	155

C1 & C2 shorter or longer if out of standard range or with damping springs

Purchase Order Data

Company:		Project:	
Purchase order no.:			
Quantity:		Tag no.:	

Operating Conditions

Fluid:			
Density:	≥ 0.55g/cm ³	g/cm ³ :	
Viscosity:	≤ 600cSt	cSt:	
Operating pressure:	max. 80bar(g) @ 20°C *1)	bar(g):	
Design pressure:	"	bar(g):	
Operating temperature:	-80°C ... 400°C *1)	°C:	
Design temperature:	"	°C:	
Connecting Distance "L":	max. 5800mm (one-piece design)	mm:	

Design and Materials

standard execution:		
Float chamber:	316&316L	
Float:	Ti-alloy	type no.:

Screws and nuts in A2-70 (AISI 304) for operating temp. -80°C ... +400°C

Damping spring, 1.4401	No.: 27399	top <input type="checkbox"/>	bottom <input type="checkbox"/>
Gaskets:	Graphite incl. reinforcing net in ss 316/316L (≤ 400°C) Standard <input type="checkbox"/>		
	Spiral wound gasket Graphit & 316 (≤ 400°C) <input type="checkbox"/>		

Process Connections

- Female thread acc. ISO7-1 resp. ISO 228-1, without plug	Rp1/2" resp. G1/2" :	<input type="checkbox"/>
- Female thread acc. ISO7-1 resp. ISO 228-1, without plug	Rp3/4" resp. G3/4" :	<input type="checkbox"/>
- Female thread acc. ISO7-1 resp. ISO 228-1, without plug	Rp1" resp. G1" :	<input type="checkbox"/>
- Female thread acc. ANSI, without plug	NPT 1/2" :	<input type="checkbox"/>
- Female thread acc. ANSI, without plug	NPT 3/4" :	<input type="checkbox"/>
- Female thread acc. ANSI, without plug	NPT 1" :	<input type="checkbox"/>
- Butt weld ends acc. to ISO/EN; 21.3 x 2.0mm; h = 25mm	DN15:	<input type="checkbox"/>
- Butt weld ends acc. to ISO/EN; 26.9 x 2.6mm; h = 26mm	DN20:	<input type="checkbox"/>
- Butt weld ends acc. to ISO/EN; 33.7 x 2.6mm; h = 34mm	DN25:	<input type="checkbox"/>
- Butt weld ends acc. to ANSI B.36.10; 21.34 x 2.77mm; h = 38mm	1/2" (Sch40):	<input type="checkbox"/>
- Butt weld ends acc. to ANSI B.36.10; 26.67 x 2.87mm; h = 41.5mm	3/4" (Sch40):	<input type="checkbox"/>
- Butt weld ends acc. to ANSI B.36.10; 33.40 x 3.38mm; h = 44.5mm	1" (Sch40):	<input type="checkbox"/>

Other Connections

--	--

Indication Rail

PC, IP65 (<150°C)	Flaps: red-silver	No.: 34837	Standard <input type="checkbox"/>
PC, IP68, inert gas (<150°C)	Flaps: red-silver	No.: 41008	<input type="checkbox"/>
Al/PC, IP54 (<250°C)	Flaps: red-silver	No.: 34560	<input type="checkbox"/>
Al/Glass, IP54 (<400°C)	Flaps: black-silver	No.: 37100	<input type="checkbox"/>
316L, IP67 (<250°C)	Flaps: red-silver	No.: 42403	<input type="checkbox"/>
316L, IP67 (<400°C)	Flaps: black-silver	No.: 42404	<input type="checkbox"/>
Special execution	Flaps: <input type="text"/>	No.: <input type="text"/>	<input type="checkbox"/>

Accessories (refer to installation instructions 20010501)

Fixation bracket No. 26936:	Quantity:	Dim. "A" [mm]:	<input type="text"/>
Magnetic switch:	Quantity:	Type:	<input type="text"/>
Transmitter:	Resolution [mm]:	Type:	<input type="text"/>
Electrical measuring length Mel [mm]:	<input type="text"/>		
Converter:	Type:	<input type="text"/>	
Additional accessories:	<input type="text"/>		

Test Reports and Certificates

EN10204:2004-3.1: main pressure-bearing parts according to PED	<input type="checkbox"/>
--	--------------------------

Special Executions & Additional Notes

<input type="text"/>

Notes:

*1) Refer to pressure-temperature rating! Lowest pressure-temperature rating of any connecting flange or fitting will set the limitation!
Test pressure will be specified according to WEKA specification AW 2.1.2.

All indicated dimensions in mm. All dimensions are only valid on VLI in standard execution.